

PROPORTIONAL FLOW VALVES AND MEASUREMENT DEVICE



DESCRIPTION	DN / Ø	FLOW RATE l/min	CONNECTION thread	DEVICE	PAGE
MEASURING DEVICE portable		0.02 ... 0.1/ 450	G¼ and G½	VGM	11.02
portable, hand-operated		0.02 ... 0.1/ 450	G¼ and G½	VGR	11.03
for many gases		0.05 ... 0.1/ 6000	G¼ - G1	PVM	11.06
with proportional regulator		0.05 ... 0.1/ 2000	G¼ - G½	PVR	11.07
differential pressure principle		0.03 ... 0.3/ 7000	G¼ - G¾	VPF	11.08
PROP. FLOW VALVES for air and water	0.1 /.../ 20	0 0.3 / 1185	G½ - G1	PV21...PV40	11.10
extremely small, 7 mW	0.3 / 0.4	0 ... 6 / 7	flange	PV630, PV631	11.12
pulse-width-modulated, mini	0.2 /.../ 0.8	0 ... 1 / 20	flange	PV202	11.13
pulse-width-modulated	1.2 /.../ 7.1	0 ... 70 / 420	G½ - G¾	PV202	11.14
stainless steel	1.2 / 7.1	0 ... 70 / 420	G½ - G¾	PV202-S	11.14
for water	12.5	0 ... 35 / 37	G¾ u. G½	PV203	11.14
motorised, for liquids	15 / 20	0 ... 1000 / 3500	G½ - G1	P8	11.15
w/o power consumption	0.2 /.../ 1.5	0 ... 3 / 24	M5	PVK	11.16
flow valve, Y-type	15 /.../ 65	0 ... 14 / 1233	G½ - G2½	PVE	11.17
NEEDLE VALVES compact	Ø 1.0 - 6.5	0 0.3 / 425	G¼ and G½	VR6	11.04
PINCH VALVES POM or Aluminium			G¾ - G3, DN150 Q		11.18



PORTABLE MASS FLOW METER, W/O MANUAL CONTROL VALVE

VGM

Prop.-V.



11

Description	Thermal mass flow meter based on high precision MEMS technology (CMOS sensor). Pressure and temperature-insensitive according to the CTA constant temperature principle. Also insensitive to pressure surges.		
Media	compressed air or non-corrosive gases	Operating pressure	max. 10 bar
Supply voltage	Standard AA battery or Micro-USB power supply (DIN62684), optionally external power +12 ...+30 V DC (max. 200 mA)		
Display	Touch-display 128 x 64 px, backlighted only with external power supply (Micro-USB or 24 V DC)		
Electrical connector	optionally length 2.0 m, with free ends at 24 V DC	Function	totalisator included, physical units can be changed
Alarm functions	3 configurable alarms, programmable as : low alarm, high alarm, window alarm and totalizer alarm. The alarms can be configured with different parameters: delay and alarm duration. Relais: switching current up to 1A, switching voltage 30 V DC		
Accuracy	± 2% FS, from 200 l/min ± 3% FS	Response time	500 ms at 99% accuracy
Turndown ratio	1:50 (Eco) or 1:1000 (Special)	Protection class	IP 50
Flow regulation	manual fine adjustment by 15 turns	Mounting position	any, horizontal from 5 bar on
Temperature range	0 °C to 50 °C / 32 °F to 122 °F	Warm-up time	< 1 sec. for full accuracy
Material	Body: aluminium, optionally electropolished stainless steel 316 Elastomer: FKM, optionally EPDM		

SST

**2... 100 ml/min/450 l/min
compressed air or gases
accurate to 2%**

Dimensions			Operating pressure	Accuracy	Connection thread	Flow rate	Order number
A	B	C					
mm	mm	mm	max. bar	%	G	ml/min / l/min	

Mass flow meter							w/o manual control valve, LCD-Display, battery mode, portable, aluminium, FKM	VGM*1
114	44	12.5	10	2	G¼	2 ... 100 ml/min	VGM-A1	
						4 ... 200 ml/min	VGM-A2	
						10 ... 500 ml/min	VGM-A5	
						0.02 ... 1 l/min	VGM-B1	
						0.04 ... 2 l/min	VGM-B2	
						0.1 ... 5 l/min	VGM-B5	
						0.2 ... 10 l/min	VGM-C1	
						0.4 ... 20 l/min	VGM-C2	
						1 ... 50 l/min	VGM-C5	
						160	54	17.5
4 ... 200 l/min	VGM-D2							
4 ... 300 l/min	VGM-D3							
9 ... 450 l/min	VGM-D4							



**VGM-G¼
mass flow meter**



**VGM-G½
mass flow meter**

Special options, add the appropriate letter oder number

deviant volume flow	indicate on order	VGM-XX
stainless steel body	electropolished throughout	VGM- . .S
EPDM elastomer	for VGM-A1 to -C5	VGM- . .E
24 V DC supply	cable attached on the device, length 2 m, with free ends	VGM- . .2
limit switch	min. / max.-alarm, 1 A SPDT switch, incl. 24 V DC supply	VGM- . .2G
panel mounting	cut-out 48 x 96 mm, protection class IP50 in the front	VGM- . .T
0.1% accuracy		VGM- . .H
carbon dioxide	CO ₂	VGM- . .03
argon	Ar	VGM- . .05
nitrogen	N ₂	VGM- . .07
helium	He	VGM- . .09
hydrogen	H ₂	VGM- . .11
methane	CH ₄	VGM- . .13
oxygen	O ₂	VGM- . .15
propane	C ₃ H ₈	VGM- . .16
nitrous oxide	N ₂ O	VGM- . .17
gases	see above	VGM- D . .
		for G½

Specific gas calibration			
gas species			max. l/min
nitrogen	07	N ₂	450
oxygen	15	O ₂	450
argon	05	Ar	300
helium	09	He	450
hydrogen	11	H ₂	300
carbon dioxide	03	CO ₂	150
propane	16	C ₃ H ₈	80
methane	13	CH ₄	100

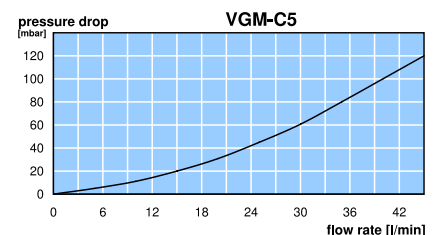
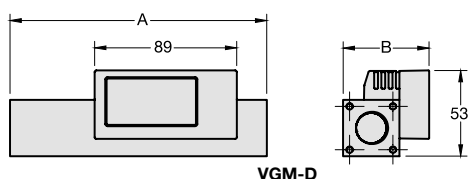
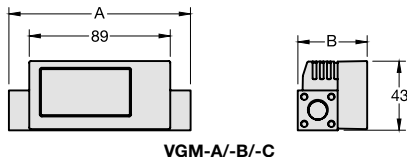

Calibration or test chart: see chapter for technical informations
*1 Note: indicate media, supply and outlet pressure on order

PDF CAD
www.aircom.net

Order example:
VGM-A1

PORTABLE MASS FLOW METER, WITH AND WITHOUT MANUAL CONTROL VALVE

VGR

Description	Thermal mass flow meter based on high precision MEMS technology (CMOS sensor). Pressure and temperature-insensitive according to the CTA constant temperature principle. Also insensitive to pressure surges.		
Media	compressed air or non-corrosive gases	Operating pressure	max. 10 bar
Supply voltage	Standard AA battery or Micro-USB power supply (DIN62684), optionally external power +12 ...+30 V DC (max. 200 mA)		
Display	Touch-display 128 x 64 px, backlit only with external power supply (Micro-USB or 24 V DC)		
Electrical connector	optionally length 2.0 m, with free ends at 24 V DC	Function	totalisator included, physical units can be changed
Alarm functions	3 configurable alarms, programmable as : low alarm, high alarm, window alarm and totalizer alarm. The alarms can be configured with different parameters: delay and alarm duration. Relais: switching current up to 1A, switching voltage 30 V DC		
Accuracy	± 2% FS, from 200 l/min ± 3% FS	Response time	500 ms at 99% accuracy
Turndown ratio	1:50 (Eco) or 1:1000 (Special)	Protection class	IP 50
Flow regulation	manual fine adjustment by 15 turns	Mounting position	any, horizontal from 5 bar on
Temperature range	0 °C to 50 °C / 32 °F to 122 °F	Warm-up time	< 1 sec. for full accuracy
Material	Body: aluminium, optionally electropolished stainless steel 316 Elastomer: FKM, optionally EPDM		

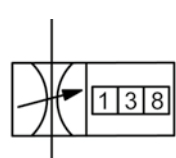

**2 ... 100 ml/min/450 l/min
compressed air or gases
accurate to 2%**

Prop.-V.
11

Dimensions			Operating pressure	Accuracy	Connection thread	Flow rate	Order number
A	B	C					
mm	mm	mm	max. bar	%	G	ml/min / l/min	

Mass flow meter			with manual control valve, LCD-Display, needle valve battery mode, portable, aluminium, FKM			VGR*1	
114	44	12.5	10	2	G¼	2 ... 100 ml/min	VGR-A1
				2		4 ... 200 ml/min	VGR-A2
				2		10 ... 500 ml/min	VGR-A5
				2		0.02 ... 1 l/min	VGR-B1
				2		0.04 ... 2 l/min	VGR-B2
				2		0.1 ... 5 l/min	VGR-B5
160	54	17.5	10	2	G½	2 ... 100 l/min	VGR-C1
				2		0.2 ... 10 l/min	VGR-C2
				2		0.4 ... 20 l/min	VGR-C5
				2		1 ... 50 l/min	VGR-D1
				2		2 ... 100 l/min	VGR-D2
				3		4 ... 300 l/min	VGR-D3
3		9 ... 450 l/min	VGR-D4				



VGR-G¼ mass flow meter with manual control valve



VGR-G½ mass flow meter

Special options, add the appropriate letter oder number

deviant volume flow	indicate on order	VGR-XX
stainless steel body	electropolished throughout	VGR-..S
EPDM elastomer	for VGR-A1 to -C5	VGR-..E
24 V DC supply	cable attached on the device, length 2 m, with free ends	VGR-..2
limit switch	min. / max.-alarm, 1 A SPDT switch, incl. 24 V DC supply	VGR-..2G
panel mounting	cut-out 48 x 96 mm, protection class IP50 in the front	VGR-..T
0.1% accuracy		VGR-..H
carbon dioxide	CO ₂	VGR-..03
argon	Ar	VGR-..05
nitrogen	N ₂	VGR-..07
helium	He	VGR-..09
hydrogen	H ₂	VGR-..11
methane	CH ₄	VGR-..13
oxygen	O ₂	VGR-..15
propane	C ₃ H ₈	VGR-..16
nitrous oxide	N ₂ O	VGR-..17
gases	see above	VGR-D...

Specific gas calibration			
gas species			max. l/min
nitrogen	07	N ₂	450
oxygen	15	O ₂	450
argon	05	Ar	300
helium	09	He	450
hydrogen	11	H ₂	300
carbon dioxide	03	CO ₂	150
propane	16	C ₃ H ₈	80
methane	13	CH ₄	100

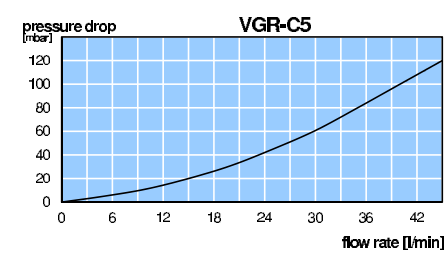
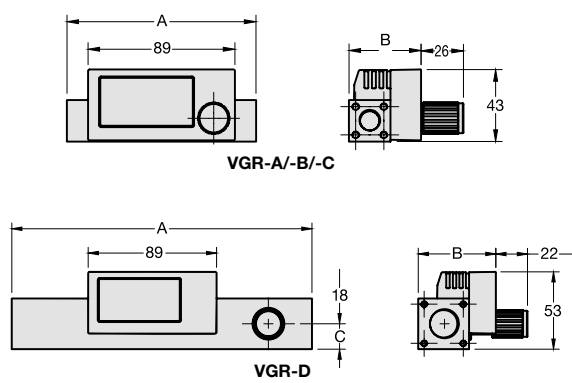

Calibration or test chart: see chapter for technical informations
*1 Note: indicate media, supply and outlet pressure on order

PDF CAD
www.aircom.net

Order example:
VGR-A1



Description	The modular, compact micro needle valve is for fine-flow adjustment of gases and liquids. It consists of an inner valve and body with straight or angle connector. The valve is free from oil and grease.	
Media	5 µm filtered compressed air, non-corrosive gases or liquids	
Operating pressure	vacuum up to positive pressure of max. 20 bar	
Adjustment	The micro valve has a 15-turn spindle to fully open from a closed condition. It operates with virtually no hysteresis and closes clockwise or optionally counterclockwise. The valve needle is non-rotating and thus provides a stable adjustment.	
Panel mounting	borehole 15 mm,	mounting through two screws M4x10
Temperature range	-20 °C to 150 °C / - 4 °F to 302 °F for FKM,	-40 °C to 150 °C / -40 °F to 302 °F for EPDM
Material	Body: anodized aluminium, optionally stainless steel Inner valve: nickel-plated brass, optionally stainless steel	Elastomer: FKM, optionally EPDM Knob: plastic

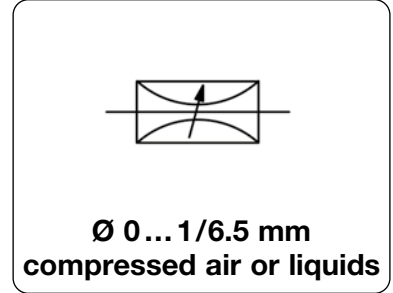

Dimensions			Needle size mm	K _v -value (m³/h)	Flow rate		Connection thread G	Order number
A	B	C			water l/min*2	air l/min*1		

Precision needle valve					with straight pass, right-hand closing, with knob, aluminium/brass/FKM, supply: max. 20 bar			VR
54	64	10	1.0	0.0007	0... 0.01	0... 0.3	G¼	VR6-02A
			1.5	0.005	0... 0.10	0... 2.5		VR6-02B
			2.0	0.01	0... 0.15	0... 7.0		VR6-02C
			2.5	0.04	0... 0.60	0... 17		VR6-02D
			3.0	0.10	0... 2.30	0... 60		VR6-02E
62	80	17.5	4.0	0.58	0... 8.00	0...250	G½	VR6-04A
			6.5	1.00	0... 16	0...425		VR6-04B



**VR6
straight-way valve**



VR6

Special options, add the appropriate letter

stainless steel body	body and valve made of stainless steel 316	for G¼	VR6-02.S
EPDM elastomer	-40 °C to 90 °C / -40 °F to 194 °F, SST body only	for G¼	VR6-02.SE
amper-proof cap	on valve with knob, standard		VR6-02.T
hexagon socket screw	and locknut		VR6-02.I

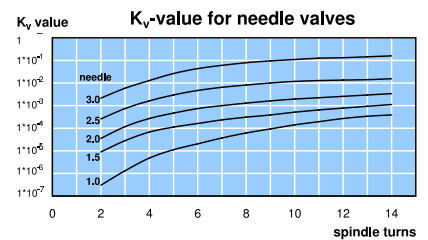
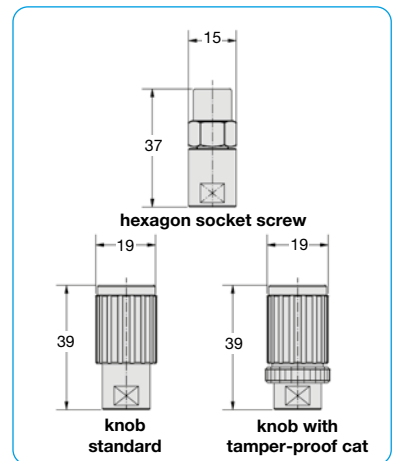
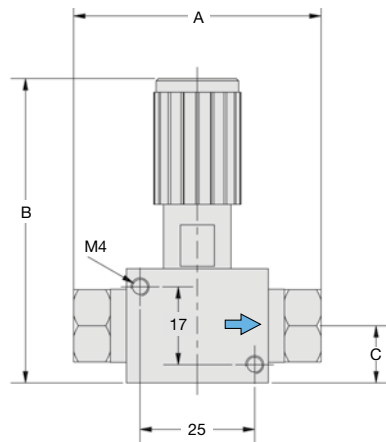

*1 at 1 bar operating pressure and open outlet
*2 at 1 bar pressure difference



Technical features

- Benefits:**
- suitable for nearly all gases and gas mixtures
 - no moving parts
 - short response time
 - unaffected of mounting position
 - optionally with unit counter and / or flow meter
 - maintenance-free
 - low pressure drop

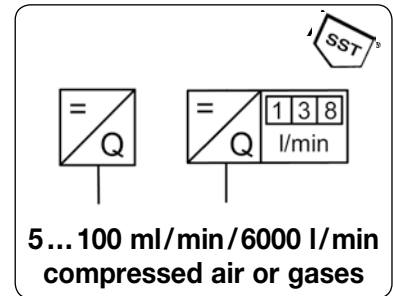

General technical features

Mounting position	any
Protection class	IP 40
Temperature range	0 °C to 50 °C / 32 °F to 122 °F
Material	Body: aluminium, optionally stainless steel 316L Elastomer: FKM, optionally EPDM or Kalrez Sensor: stainless steel 316L Filter/strainer: stainless steel

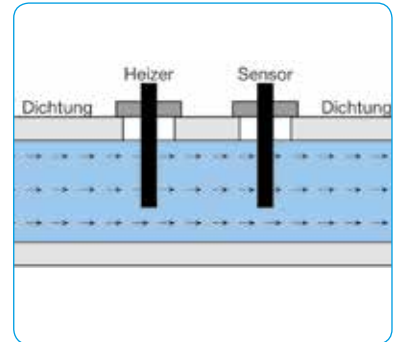

functional principle

Pneumatic features

Media	compressed air as well as virtually all gases and mixtures of gases
Operating pressure	max. 10 bar
Differential pressure	max. 5 bar
Mass flow rate	0 ... 100 ml/min / 2000 l/min, for PVR 0 ... 100 ml/min / 6000 l/min, for PVM

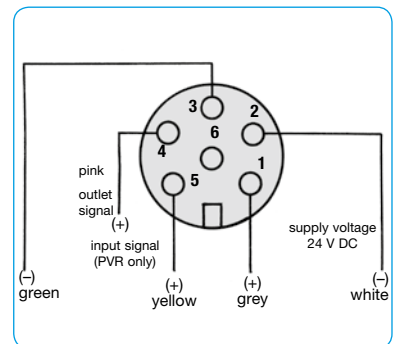

PVM and PVR connecting plan

Electrical features

Supply voltage	24 V DC + 10%
Current consumption	max. 75 mA for PVM 11, all other devices max. 250 mA
Signal ranges	4-20 mA, optionally 0 ... 5 V DC
Impedance	> 10 kΩ at voltage signal, < 375 Ω at current signal
Connection	round connector M16x1, 6-pin
EMC	according to CE
Note	at < 100 mbar inlet path is required (PVM only)

model gas	PVM23 - PVM27	PVM11
air	1.00	1.00
argon	2.01	1.40
CO ₂	1.20	0.74
helium	/	1.41
hydrogen	/	1.01
NH ₃	0.80	0.77
N ₂ O ₂	1.00	1.00
C ₂ H ₂	0.75	0.61
C ₃ H ₆	/	0.34
C ₃ H ₈	0.63	0.34
CH ₄	0.67	0.76
CO	1.04	1.00
C ₂ H ₄	0.89	0.60
NO	1.02	0.97
HCL	1.58	0.99

conversion factors for max. flow rate
for other gases

Accuracy

Linearity / Hysteresis	> ± 3 % FS
Repeatability	> ± 0.5% FS
Pressure sensitivity	> ± 0.3% FS/bar typ. (air)
Temperature sensitivity	< ± 0.3% / °C (air)
Mounting sensitivity	< 0.3% FS at 90°
Operating time	25 s at 100% of the range
Tightness	< 2 x 10 ⁻⁸ mbar l/s He

Description	Mass flow meter directly measuring flow according to constant temperature anemometer principle. PVM 11 measures via a bypass, the other types measure the flow directly.
Features	Low pressure drop and immunity against dirt and humidity. Measurement unaffected by pressure and temperature changes. No moving parts, installation in virtually any position.
Principle	Two stainless steel probes - a heater and temperature probe - protrude inside the bore. A constant difference in temperature is created. The energy required is proportional to flow.
Media	compressed air, air as well as virtually all gases and gas mixtures
Compensation	Neither temperature nor pressure have to be compensated. There are no moving parts within the flow meter, therefore it is virtually wear-free.
Pressure drop	Low pressure drop because solely two stainless steel probes protrude inside the smooth, round measurement cell. The use of screw connections with a nominal size as big as possible is suggested.
Temperature range	0 °C to 50 °C / 32 °F to 122 °F
Material	Body: aluminium, optionally SST 316L Sensor: stainless steel 316L
	Operating press. max. 10 bar Differential press. max. 5 bar Elastomer: FKM, optionally EPDM or Kalrez Filter/strainer: stainless steel

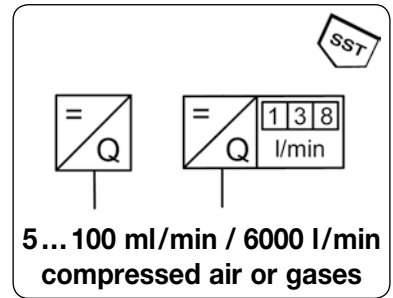

Dimensions			Operating pressure max. bar	Connection thread G	Flow rate ml/min*1 / l/min*1	Order number
A	B	C				

Mass flow meter				4-20 mA output signal, supply voltage 24 V DC, w/o display, with coupling socket, for compressed air	PVM*2	
95	94.5	15	10	G1/4	5 ... 100 ml/min 10 ... 200 ml/min 25 ... 500 ml/min 50 ... 1000 ml/min	PVM11-12 PVM11-22 PVM11-52 PVM11-13
95	94.5	15	10	G1/4	0.10 ... 2 l/min 0.25 ... 5 l/min 0.50 ... 10 l/min	PVM11-23 PVM11-53 PVM11-14
95	94.5	15	10	G1/4	1 ... 20 l/min 2 ... 50 l/min 5 ... 100 l/min	PVM23-24 PVM23-54 PVM23-15
95	98.5	15	10	G1/2	5 ... 100 l/min 10 ... 200 l/min 20 ... 400 l/min	PVM25-15 PVM25-25 PVM25-45
116	123	25	10	G1/2	20 ... 400 l/min 50 ... 1000 l/min 100 ... 2000 l/min	PVM27-45 PVM27-16 PVM27-26
130	143	35	10	G1	150 ... 2000 l/min 200 ... 4000 l/min 250 ... 5000 l/min	PVM28-26 PVM28-46 PVM28-56



PVM23



PVM27

Special options, add the appropriate letter order number

special calibration	range or gas to be indicated on order	PVM Y
monitor signal	0-5 V, load resistance > 10 kΩ	PVM U
stainless steel body	316L	PVM S
		PVM S
EPDM elastomer		PVM E
Kalrez elastomer		PVM K
free of oil and grease	for oxygen and different gases	PVM L
carbon dioxide CO₂	03	argon Ar: 05
helium He	09	hydrogen H ₂ : 11
nitrogen N₂		methane CH ₄ : 13
oxygen O₂	15	propane C ₃ H ₈ : 16
		nitrous oxide N ₂ O: 17
		PVM 07
		PVM 13
		PVM 17

Accessories, enclosed

coupling socket	M16x1, 6-pin with 3 m Kabel	straight	KM16-A6-3
other cable length	5 m or 10 m available		

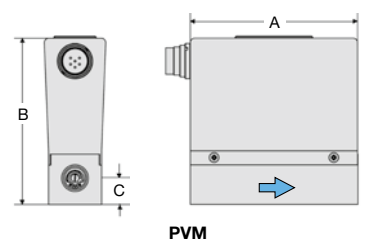

PVM

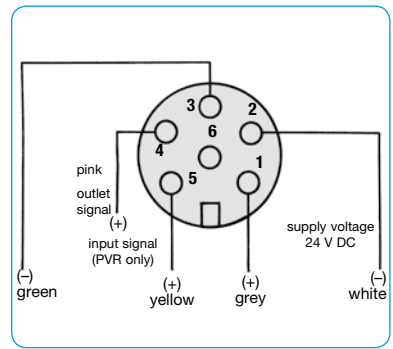

connecting plan

*1 valid for compressed air at Δp= 5 bar and open outlet. For other gases please apply conversion factor



Description	Mass flow meter directly measuring flow according to constant temperature anemometer principle. The measured setpoint is compared with the nominal value. The valve will be readjusted accordingly.		
Mechanical Construction	PVR11/12/23: mass flow meter and meter in the same housing PVR 25: mass flow meter and meter together at the measuring bob PVR27: mass flow meter and meter as single components are bolted together		
Media	compressed air, air as well as virtually all gases and gas mixtures		
Compensation	Neither temperature nor pressure have to be compensated. There are no moving parts within the flow meter, therefore it is virtually wear-free.		
Pressure drop	Low pressure drop because solely two stainless steel probes protrude inside the smooth, round measurement cell. The use of screw connections with a nominal size as big as possible is suggested.		
Temperature range	0 °C to 50 °C / 32 °F to 122 °F Operating press. max. 10 bar Differential press. max. 5 bar		
Material	Body: aluminium, optionally SST 316L Elastomer: FKM, optionally EPDM or Kalrez Sensor: stainless steel 316L Filter/strainer: stainless steel		

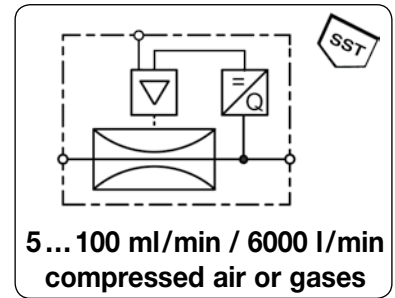

Dimensions			K _v -value (m ³ /h)	Operating pressure max. bar	Connection thread G	Mass flow ml/min*1 / l/min*1	Order number
A	B	C					

Mass flow regulator							4-20 mA input and output signal, supply voltage 24 V DC, w/o display, with coupling socket, for compressed air	PVR*3
95	94.5	15	0.066	10	G¼	5 ... 100 ml/min	PVR11-12	
						10 ... 200 ml/min	PVR11-22	
						25 ... 500 ml/min	PVR11-52	
						50 ... 1000 ml/min	PVR11-13	
95	94.5	15	0.066	10	G¼	0.10 ... 2 l/min	PVR11-23	
						0.25 ... 5 l/min	PVR11-53	
						0.50 ... 10 l/min	PVR11-14	
95	97	15	0.066	10	G¼*2	0.50 ... 10 l/min	PVR12-14	
						1.00 ... 20 l/min	PVR12-24	
						2.50 ... 50 l/min	PVR12-54	
95	94.5	15	0.066	10	G¼	1 ... 20 l/min	PVR23-24	
						2 ... 50 l/min	PVR23-54	
					G½	5 ... 100 l/min	PVR23-15	
145	132	16	0.30	10	G½	5 ... 100 l/min	PVR25-15	
						10 ... 200 l/min	PVR25-25	
						20 ... 400 l/min	PVR25-45	
257	163	25	1.0	10	G½	25 ... 400 l/min	PVR27-45	
						50 ... 1000 l/min	PVR27-16	
						100 ... 2000 l/min	PVR27-26	

PVR23

PVR25

Special options, add the appropriate letter order number

special calibration	range or gas to be indicated on order			PVRY
setpoint /monitor signal	0-5 V, load resistance > 10 kΩ			PVRU
stainless steel body	316L			PVRS
EPDM elastomer				PVRE
Kalrez elastomer				PVRK
free of oil and grease	for oxygen and different gases			PVRL
potentiometer in cover	for flow regulation, height +40 mm			PVRX67
carbon dioxide CO₂	03	argon Ar:	05	nitrogen N₂:
helium He:	09	hydrogen H₂:	11	methane CH₄:
oxygen O₂:	15	propane C₃H₈:	16	nitrous oxide N₂O:
				PVR07
				PVR13
				PVR17

Accessories, enclosed

coupling socket M16x1, 6-pin with 3 m Kabel straight **KM16-A6-3**
other cable length 5 m or 10 m available

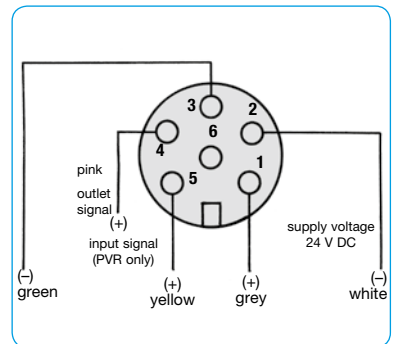
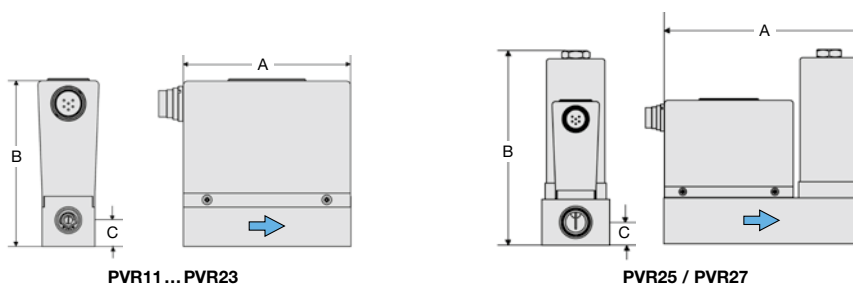

connecting plan

*1 valid for compressed air at Δp= 5 bar and open outlet. For other gases please apply conversion factor.
 *2 connection thread G½ on the input side

*3 Note: indicate media, supply and outlet pressure, temperature on order

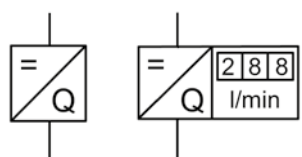

Description	The flow measurement device works with differential pressure technology. It allows active flow control through continuous real time measurement, realised within 1 ms. There are no moving parts within the flow monitor, therefore it is virtually wear-free.		
Media	compressed air		
Operating pressure	max. 11 bar		
Supply voltage	15...24 V DC, max. power consumption 80 mA		
Display	without display as standard, optionally 4-digit LCD display with 12 mm tall, red figures		
Electrical connector	square connector, 6-pin with coupling socket		
Output signal	0...10 V, optionally 4...20 mA or 20...4 mA		
Repeatability	< 0.25% FS		
Detectable flow	> 4% FS		
Response time	1 ms		
Mounting position	any		
Material	Body:	anodized aluminium	
	Transducer:	aluminium	
	Accuracy	< 4% FS at 10% to 100% range	
	Temperature sensitivity	0.25% per °C / K	
	Shock resistance	25 g	
	Protection class	IP 54 / Nema 4	
	Temperature range	0 °C to 50 °C / 32 °F to 122 °F	
	Elastomer:	NBR/Buna-N	



**30...300 / 7000 l/min
compressed air, 1 ms fast**

Dimensions			Operating pressure	Connection thread	Flow rate	Order number
A	B	C				
mm	mm	mm	max. bar	G	ml/min*1	

Flow meter						for compressed air, 0...10 V output signal, supply 24 V DC, without display, with coupling socket, open outlet	VPF
102	106	10	11	G¼	30...300		VPF-2
102	119	19	11	G¾	70...700		VPF-3
102	119	19	11	G½	300...3000		VPF-4
102	132	25	11	G¾	700...7000		VPF-5

Special options, add the appropriate letter or number

monitor signal	4-20 mA, proportional to flow rate increase	VPF- . I
	20-4 mA, proportional to flow rate increase	VPF- . L
LED display	4-digit, red figures 12 mm tall	VPF- . A
carbon dioxide	CO ₂	VPF- . 03
argon	Ar	VPF- . 05
nitrogen	N ₂	VPF- . 07
helium	He	VPF- . 09



VPF

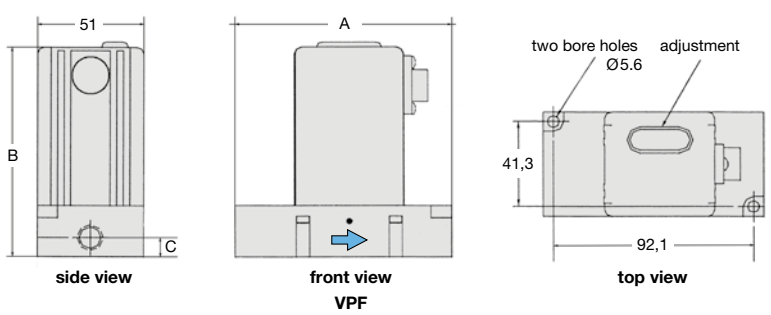

*1 at 10 bar operating pressure and open outlet

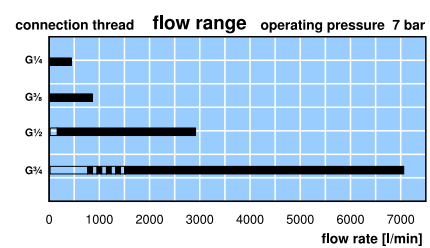
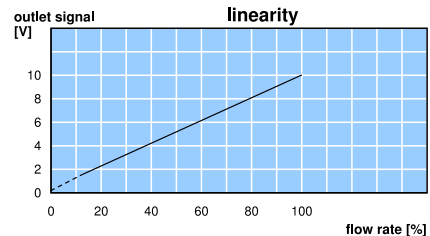
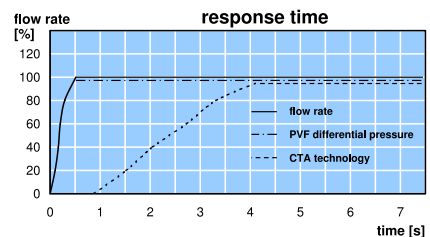

Description	2-way proportional flow valve controls the volume flow of maximum 1185 l/min for air in proportion to the input signal of 0 to 10 V or 0/4 to 20 mA. The proportional valve and the electronic control unit are ordered separately.
Product selection	To achieve the best linear flow characteristics, it is advisable not to reduce the flow too much and to have enough pressure drop at the valve for good control. Reference value: at the valve > 30% of the total pressure drop.
Installation hint	The nominal width of the orifice following the proportional valve should not be smaller than the nominal width of the valve. A constriction of the cross-section after the valve should be categorically avoided!

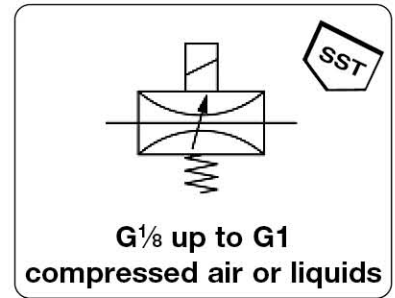

General technical features

Design	2-way proportional flow valve, normally closed during absence of current, with additional control module in cable plug or in housing for DIN rail mounting.		
Mounting position	any, preferably upright		
Protection class	IP 65 with coupling socket, IP 40 for DIN rail version		
Temperature range	-10 °C to 90 °C / 14 °F to 194 °F for media -10 °C to 55 °C / 14 °F to 131 °F for electronics		
Material	Body: brass Elastomer:	Inner valve: FKM	brass and stainless steel Control housing: plastic

Pneumatic features

Media	compressed air, non-corrosive gases or liquids, max. viscosity 21 mm ² /s, PV40 for liquids only
Operating pressure	see chart, max. 16 bar
Flow rate	0...2 / 1185 l/min for air, 0...0.03 / 83 l/min for liquids in detail see chart, at max. supply pressure and Δp = 1 bar

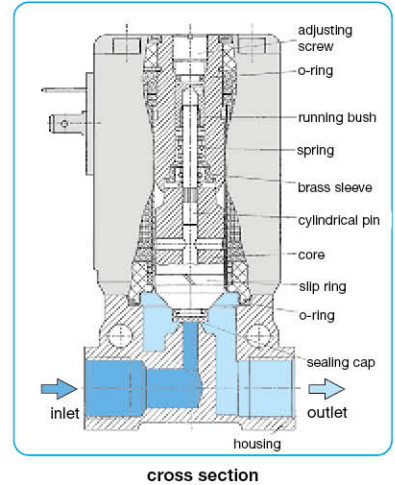

Electrical features

Supply voltage 24 V DC ± 10%, residual ripple max. 5%, with reverse voltage protection

Power consumption	electronic	PV21	PV21	PV22	PV34	PV40-04	PV40-06	PV40-08
	1 W	2 W to DN 0.6	5 W from DN 0.8 on	9 W	16 W	8 W	10 W	15 W

Command signal 0-5 V, 0-10 V, 0-20 mA or 4-20 mA selectable

Impedance > 20 kΩ at voltage signal
< 200 Ω at current signal

Electrical connector PV21: square connector according to DIN 43650 form B
PV22...PV40: square connector according to DIN 43650 form A

Accuracy

Linearity	< 10 % FS		
Hysteresis	< 5 % FS		
Response sensitivity	< 0.1% FS at DN < 0,8 mm,	< 0.25% FS at DN ≥ 0,8 mm,	< 1% FS at PV40
Repeatability	< 0.25% FS at PV22 < 0.5% FS		
Regulating time	PV21: < 15 ms,	PV22: < 20 ms,	PV34: < 50 ms, PV40: < 200 ms each for 90% of the range

Adjustment

Zero point	The zero point can be decreased or increased.
Range	The range can be decreased or increased.
Ramp	The ramping potentiometer adjusts the time delay with a range of 0 to 10 s in order to dampen sudden changes of the setpoint. Increasing and decreasing ramps have the same delay.
Zero point switch	Using a DIP switch, the zero point switch can be activated or deactivated. It is not necessary to have another switch-off valve.

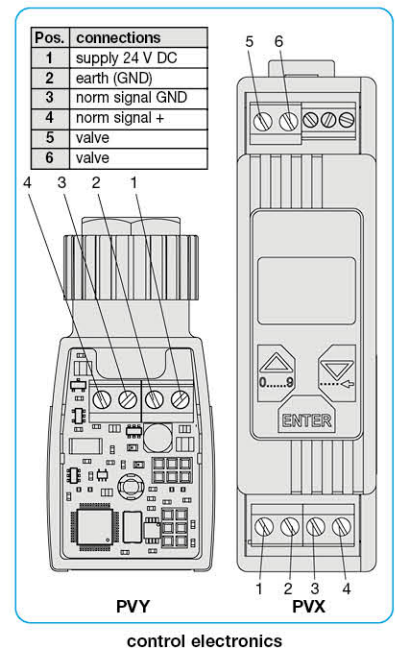

Technical features	
• Media	compressed air, non-corrosive gases or liquids, except for PV40
• Signal range	0-5 V, 0-10 V, 0-20 mA, 4-20 mA
• Pressure range	vacuum ... 2 / 16 bar
• Orifice	DN 0.1 ... DN 20
• Flow rate	max. 1185 l/min for air, max. 90 l/min for water
• Adjustment	zero point, range and ramp
• Zero switch-off	ensures reliable closure of the valve
• Linearity	< 10% FS
• Hysteresis	< 5% FS
• Response sensitivity	< 0.1% FS at DN < 0.8 mm < 0.25% FS at DN ≥ 0.8 mm < 1% FS at PV40
• Repeatability	< 0.25% FS, < 0.5% FS at PV22
• Regulating time	depending on type: < 15 ms, < 20 ms, < 50 ms or < 200 ms
• Protection class	IP65 with plug
• Impedance	> 20 kΩ at V, < 200 Ω at mA

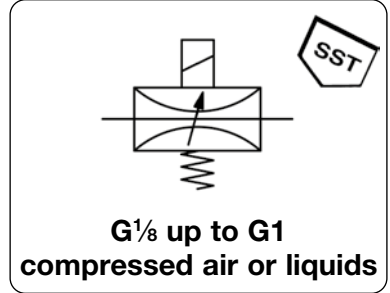

Dimensions		Nominal K _v -	Flow rate		Operating	Differ.-	Connection		Order
A	B	size	water	air	pressure	press.	thread	number	
mm	mm	DN (m ³ /h)	l/min*1	l/min*2	max. bar	max. bar	G		

Proportional flow valve											without electronics, brass, FKM, for compressed air, vacuum or liquids*2	PV
25	50	7	0.1	0.0025	0...	0.004	0...	0.27	10	10	G1/8	PV21-01
25	50	7	0.2	0.001	0...	0.017	0...	1.0	10	10	G1/8	PV21-02
25	50	7	0.3	0.002	0...	0.033	0...	2.2	10	10	G1/8	PV21-03
25	50	7	0.4	0.004	0...	0.067	0...	4.0	8	8	G1/8	PV21-04
25	50	7	0.6	0.010	0...	0.167	0...	11	6	6	G1/8	PV21-06
25	50	7	0.8	0.018	0...	0.3	0...	19	12	6	G1/8	PV21-08
25	50	7	0.8	0.018	0...	0.3	0...	19	12	12	G1/8	PV21-08B
25	50	7	1.0	0.027	0...	0.3	0...	19	10	5	G1/8	PV21-10
25	50	7	1.0	0.027	0...	0.3	0...	19	10	10	G1/8	PV21-10B
25	50	7	1.2	0.038	0...	0.633	0...	41	8	4	G1/8	PV21-12
25	50	7	1.2	0.038	0...	0.633	0...	41	8	8	G1/8	PV21-12B
25	50	7	1.6	0.055	0...	0.917	0...	59	6	3	G1/8	PV21-16
25	50	7	1.6	0.055	0...	0.917	0...	59	6	6	G1/8	PV21-16B
25	50	7	2.0	0.090	0...	1.5	0...	97	3	1.5	G1/8	PV21-20
25	50	7	2.0	0.090	0...	1.5	0...	97	3	3	G1/8	PV21-20B
32	66	8.5	0.8	0.018	0...	0.3	0...	19	16	8	G1/8	PV22-08
32	66	8.5	0.8	0.018	0...	0.3	0...	19	16	16	G1/8	PV22-08B
32	66	8.5	1.0	0.027	0...	1.0	0...	65	14	7	G1/8	PV22-10
32	66	8.5	1.0	0.027	0...	1.0	0...	65	14	14	G1/8	PV22-10B
32	66	8.5	1.2	0.040	0...	0.67	0...	43	12	6	G1/8	PV22-12
32	66	8.5	1.2	0.040	0...	0.67	0...	43	12	12	G1/8	PV22-12B
32	66	8.5	1.5	0.060	0...	1.0	0...	65	10	5	G1/8	PV22-15
32	66	8.5	1.5	0.060	0...	1.0	0...	65	10	10	G1/8	PV22-15B
46	72	8.5	2.0	0.10	0...	1.66	0...	108	8	4	G1/4	PV22-20
46	72	8.5	2.0	0.10	0...	1.66	0...	108	8	8	G1/4	PV22-20B
46	72	8.5	2.5	0.15	0...	2.5	0...	162	5	2.5	G1/4	PV22-25
46	72	8.5	2.5	0.15	0...	2.5	0...	162	5	5	G1/4	PV22-25B
46	72	8.5	3.0	0.22	0...	3.67	0...	237	3.5	1.8	G1/4	PV22-30
46	72	8.5	3.0	0.22	0...	3.67	0...	237	3.5	3.5	G1/4	PV22-30B
46	72	8.5	4.0	0.32	0...	5.33	0...	345	2	1	G1/4	PV22-40
46	72	8.5	4.0	0.32	0...	5.33	0...	345	2	2	G1/4	PV22-40B



PV21



PV22

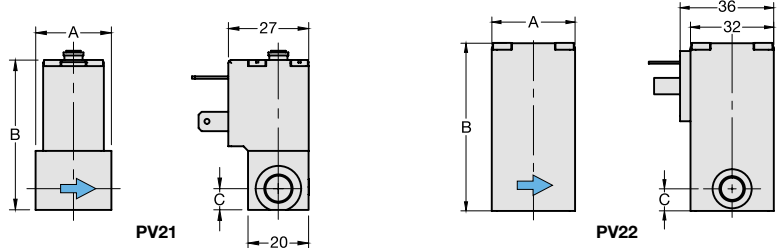

*1 at max. operating pressure and Δp = 1 bar *2 at pressure drop from 6 bar down to 5 bar

Technische Daten: siehe vorherige Seite

PDF CAD
www.aircom.net

Order example:
PV21-01

PROPORTIONAL FLOW VALVE "AIRPROP"®

PV21 ... PV40

Media		Technical features	
compressed air, non-corrosive gases or liquids, except for PV40		Linearity	< 10% FS
Signal range	0-5 V, 0-10 V, 0-20 mA, 4-20 mA	Hysteresis	< 5% FS
Pressure range	vacuum...2 / 16 bar	Response sensitivity	< 0.1% FS at DN < 0.8 mm < 0.25% FS at DN ≥ 0.8 mm < 1% FS at PV40 < 0.25% FS, < 0.5% FS at PV22
Orifice	DN 0.1 ... DN 20	Repeatability	< 0.25% FS, < 0.5% FS at PV22
Flow rate	max. 1185 l/min for air, max. 90 l/min for water	Regulating time	depending on type: < 15 ms, < 20 ms, < 50 ms or < 200 ms
Adjustment	zero point, range and ramp	Protection class	IP65 with plug
Zero switch-off	ensures reliable closure of the valve	Impedance	> 20 kΩ at V, < 200 Ω at mA

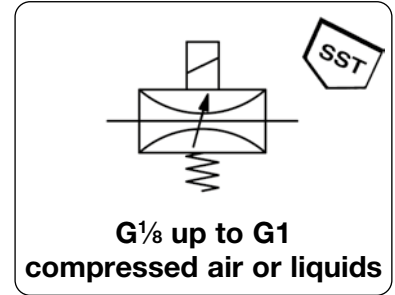

Prop.-V.
11

Dimensions			Nominal K _v -	Flow rate		Operating	Differ.-	Connection	Order	
A	B	C	size	value	water	air	pressure	press.	thread	number
mm	mm	mm	DN	(m³/h)	l/min*1	l/min*2	max. bar	max. bar	G	

Proportional flow valve										without electronics, brass, FKM, for compressed air, vacuum or liquids*2	PV
55	105	11	4.0	0.45	0... 7.5	0... 485	8	4	G ³ / ₈		PV34-40
55	105	11	4.0	0.45	0... 7.5	0... 485	8	8	G ³ / ₈		PV34-40B
55	105	11	6.0	0.80	0... 13.3	0... 860	4	2	G ¹ / ₂		PV34-60
55	105	11	6.0	0.80	0... 13.3	0... 860	4	4	G ¹ / ₂		PV34-60B
55	105	11	8.0	1.10	0... 18.3	0... 1185	2	1	G ¹ / ₂		PV34-80
55	105	11	8.0	1.10	0... 18.3	0... 1185	2	2	G ¹ / ₂		PV34-80B
50	89	12	10	1.4	0... 25.0*3	-	10		G ¹ / ₂		PV40-04
58	110	14	13	2.5	0... 45.0*3	-	10		G ³ / ₄		PV40-06
80	155	16	20	5.0	0... 90.0*3	-	10		G1		PV40-08



PV34



PV40

Special options, add the appropriate letter
stainless steel body SST 316, W.-No. 1.4401 for PV21 to PV34 PV...S

Accessories, enclosed
plug electronics 24 V DC, 0-5 V, 0-10 V, 0/4 mA-20 mA for PV22 to PV40 **PVY-06**
clip-on electronics 24 V DC, 0-5 V, 0-10 V, 0/4 mA-20 mA for PV21 **PVX-01**
for PV22 to PV40 **PVX-02**
coupling socket according to DIN 43650 form B for PV21 **2285-0**
according to DIN 43650 form A for PV22 to PV40 **2286-0**



PVY

PVX

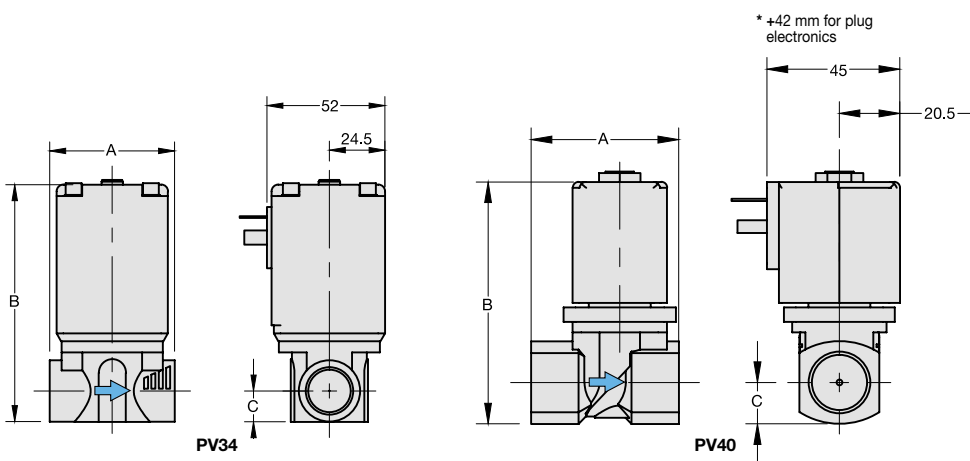

*1 at max. operating pressure and Δp = 1 bar *2 at pressure drop from 6 bar down to 5 bar
*3 PV40 is not suitable for compressed air and vacuum, since pilot-controlled

Technical informations: see previous page PDF CAD www.aircom.net

Order example: PV34-40

Description	The piezo miniature flow valve is highly reliable and combines precise control of flow rates with power consumption under 7 mW. It is extremely compact and weighs only 23 g. Therefore, it is very suitable for battery-operated portable devices. Preferred application in medical engineering. Electronics are not necessary.	
Media	50 µm filtered compressed air or non-corrosive gases	
Flange connection	according to CNOMO E06.36.120N (15 x 15 mm) or CNOMO E06.05.80 (30 x 30 mm) with adapter see chart, max. 8 bar	
Operating pressure	0...40 V DC, residual ripple < 10%, without reverse voltage protection	
Supply voltage	plug, contact gap 9.4 mm, 3-pin, with coupling socket (Pg 7P), optionally with wire, red (+), black (-)	
Electrical connector	Note: The current is to be limited by a > 30 Ω resistor connected in series.	
Note	< 1 billion switching cycles at 6 bar	
Life cycle		
Power consumption	< 100 µA, i.e. 7 mW	Switch-on consumption 0.6 W
Response time	50 ms	Protection class IP 65 with coupling socket
Mounting position	any	Temperature range 0 °C to 60 °C / 32 °F to 140 °F
Material	Body: PPS plastic	Elastomer: NBR/Buna-N
	Inner valve: piezoelectric ceramics	Manifold block: brass (M5), zinc die-cast (G½), polyamide (Ø4)

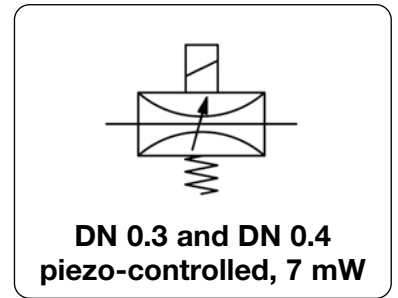

Description	Dimensions			K _v -value	Flow rate	Operating pressure	Nominal size	Order number
	A	B	C	(m³/h)	l/min*1	max. bar	DN	
	mm	mm	mm					

Flow valve	flangeable without manifold block, with coupling socket, 0-40 V DC								PV630
	NC	A	B	C	K _v -value	Flow rate	Operating pressure	Nominal size	
		15	48	51	0.005	0...6	8	0.3	PV630-03
					0.006	0...7	4	0.4	PV630-04
	NO	15	48	51	0.005	0...6	8	0.3	PV631-03
					0.006	0...7	4	0.4	PV631-04



Special options, add the appropriate letter

w/o coupling socket protection class IP00 PV63.-0.X

with wire length 1 m, red (+), black (-) PV63.-0.L



Accessories, enclosed

manifold block M5 AP-01

G½ AP-02

Ø4 AP-03

in-line manifold block Ø4 AP-04

G½ AP-05

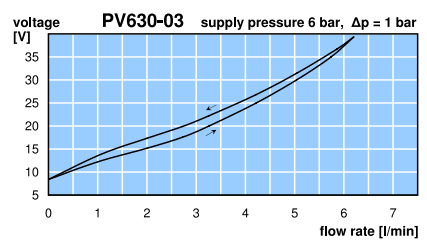
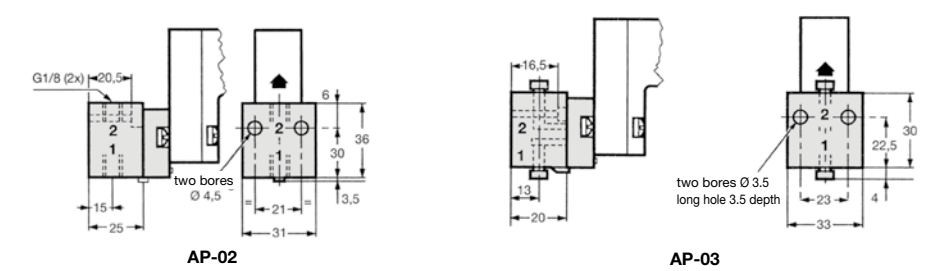
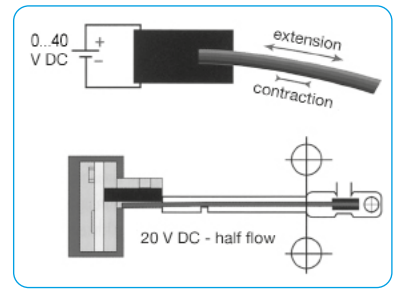
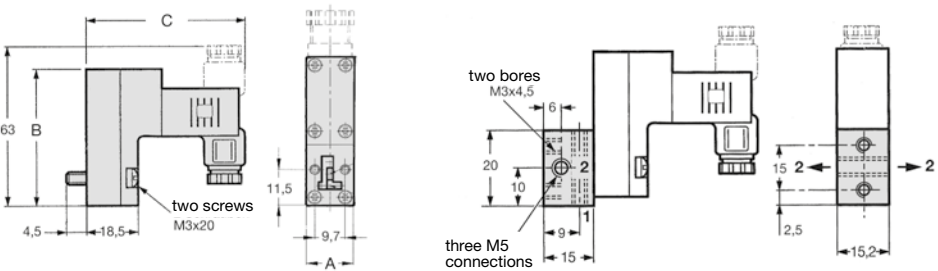

*1 at operating pressure 6 bar and Δp = 1 bar

Description	The miniature flow valve is highly reliable and combines precise control of flow rate with compact design and only 80 g weight. It can be used for vacuum or pressure up to 12 bar. Plug amplifier required.		
Media	50 µm filtered compressed air, vacuum or non-corrosive gases		
Plug amplifier	Conversion of the analogue signal into a pulse-wide modulated current.		
	Supply voltage: 24 V DC, max. 1.1 A	Adjustment:	zero point and range
	Switchable signal: 0...10 V, 0...20 mA, 4...20 mA	Time ramp:	0.1 to 3 s selectable
	Close function: < 2% of max. signal	Frequency:	1000 Hz
Electrical connector	plug, contact gap 9.4 mm, 3-pin, with coupling socket (Pg 7P)		
Operating pressure	see chart, max. 10 bar		
Repeatability	< 3% FS		
Response sensitivity	< 2% FS		
Polarity	any for valve		
Mounting position	any		
Material	Body: brass	Elastomer: FPM	Manifold: brass (M5), zinc die-cast (G½), polyamide (Ø4)
	Inner valve: stainless steel and brass		

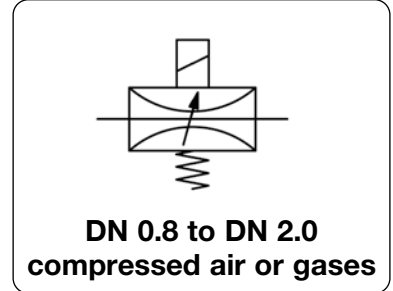

Prop.-V.
11

Description	Dimensions			K _v -value (m ³ /h)	Flow rate l/min*1	Operating pressure max. bar	Nominal size DN	Order number
	A	B	C					

Proportional flow valve	flangeable, for compressed air, 24 V DC,	w/o manifold block, direct control, w/o amplifier	with coupling socket, direct control, w/o amplifier	PV202				
				NC	NC			
	15	48	53	0.0012	0... 1	10	0.2	PV202-002
				0.0048	0... 5	10	0.4	PV202-004
				0.0096	0... 11	10	0.6	PV202-006
				0.0180	0... 20	10	0.8	PV202-008



PV202

Special options, add the appropriate letter

12 V DC	voltage signal	PV202-0..V
---------	----------------	------------



PV202
accessory: manifold block M5

Accessories, enclosed

plug amplifier	24 V DC, switchable 0-10 V, 0-20 mA, 4-20 mA	PVY-05
manifold block	M5	AP-01
	G½	AP-02
	Ø4	AP-03
in-line manifold	Ø4	AP-04
	G½	AP-05



PVY-05

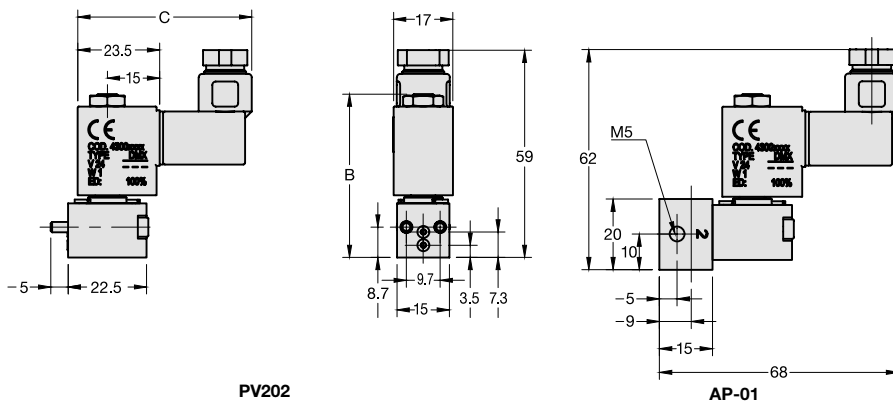

PV202

AP-01

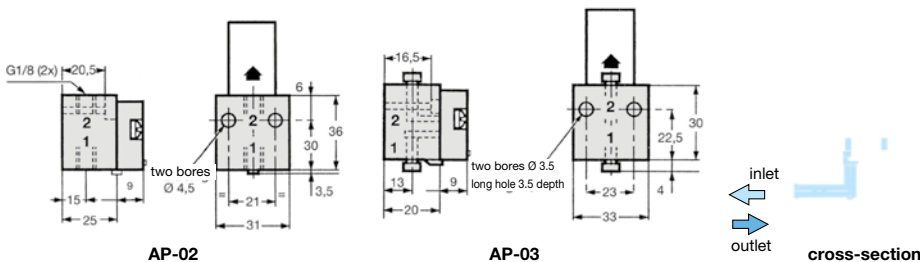

AP-02

AP-03

cross-section

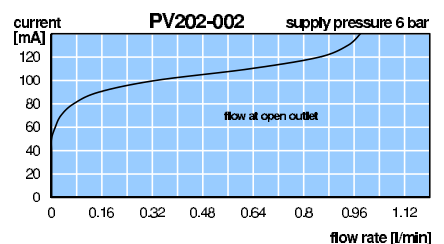
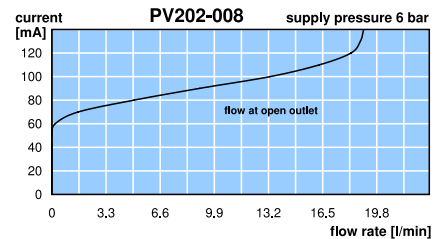

*1 operating pressure 6 bar and Δp = 1 bar

More miniature valves: see catalogue MV, also in ATEX version

PDF CAD
www.aircom.net

Order example:
PV202-002

PROPORTIONAL FLOW VALVE

PV202 / PV203

Prop.-V.



11

Description	The proportional flow valve can be controlled either by 24 V DC or optionally by a plug amplifier with switchable signals. 50 µm filtered compressed air, vacuum, non-corrosive gases or liquids Conversion of the analogue signal into a pulse-wide modulated current.		
Media	24 V DC, max. 1.1 A		
Plug amplifier	Adjustment: zero point and range		
	Switchable signal: 0...10 V, 0...20 mA, 4...20 mA		Time ramp: 0.1 to 3 s selectable
	Close function: < 2% of max. signal		Hum frequency: 40 to 700 Hz selectable
Electrical connector	plug, 3-pin, with coupling socket (Pg 9P or PG 11P)		
Protection class	IP 65 with coupling socket		
Temperature range	-10 °C to 90 °C / 14 °F to 194 °F at G $\frac{1}{2}$: 0 °C to 50 °C / 32 °F to 122 °F		
Viscosity max.	PV202, G$\frac{1}{8}$	PV202, G$\frac{1}{4}$ / G$\frac{3}{8}$	PV203, G$\frac{3}{8}$ / G$\frac{1}{2}$
Power consumption	100...450 mA, 8.6 W	100...500 mA, 11 W	100...500 mA, 11 W
Hysteresis / Sensitivity	< 5% FS / < 1% FS	< 5% FS / < 2% FS	< 7.5% FS / < 2% FS
Repeatability	< 1% FS	< 3% FS	< 3% FS
Body / Inner valve	brass/SST, PTFE, FKM	brass/SST, PTFE, FKM	brass/SST, PTFE, NBR/Buna-N

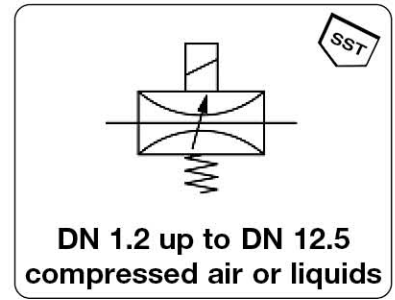

Dimensions			Media	Nominal size	K _v -value	Flow rate	Supply max.	Connection thread	Order number
A	B	C	A: air W: water	DN	(m ³ /h)	l/min*1	bar	G	

Proportional flow valve									
24 V DC, direct control, without amplifier, with coupling socket, made of brass									
PV202 / PV203									
25	78	8	A	1.2	0.05	0... 70	8.0	G $\frac{1}{8}$	PV202-1-12
					0.07	0...110	6.0	PV202-1-16	
					0.13	0... 70	4.0	PV202-1-24	
					0.18	0...105	2.5	PV202-1-32	
40	95	20	A/W*3	1.2	0.05	0... 60	16	G $\frac{1}{4}$	PV202-2-12
					0.12	0...110	8.0	PV202-2-24	
					0.24	0...170	4.0	PV202-2-32	
					0.42	0...280	2.5	PV202-2-40	
					0.72	0...310	1.4	PV202-2-56	
48	97	14	A/W*3	3.2	0.24	0...190	4.0	G $\frac{3}{8}$	PV202-3-32
					0.42	0...300	2.5	PV202-3-40	
					0.72	0...330	1.4	PV202-3-56	
					0.90	0...420	1.0	PV202-3-71	
52	105	14	W	12.5	2.10	0... 35*2	10	G $\frac{3}{8}$	PV203-3-125W
					2.10	0... 37*2	10	G $\frac{1}{2}$	PV203-4-125W



Special options, add the appropriate letter

for water or oil for PV202, G $\frac{1}{4}$ and G $\frac{3}{8}$ PV202-.-.W
 stainless steel body NPT connection thread, FKM elastomere for PV202 PV202-.-.S
 12 V DC voltage signal PV20-.-.-.12V

Accessories, enclosed

plug amplifier 24 V DC, switchable 0-10 V, 0-20 mA, 4-20 mA for PV202, G $\frac{1}{8}$ PVY-03
 for all others PVY-04
 plug amplifier 12 V DC, switchable 0-10 V, 0-20 mA, 4-20 mA für PV202, G $\frac{3}{8}$ PVY-08
 for all others PVY-09

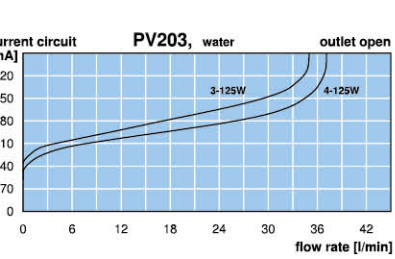
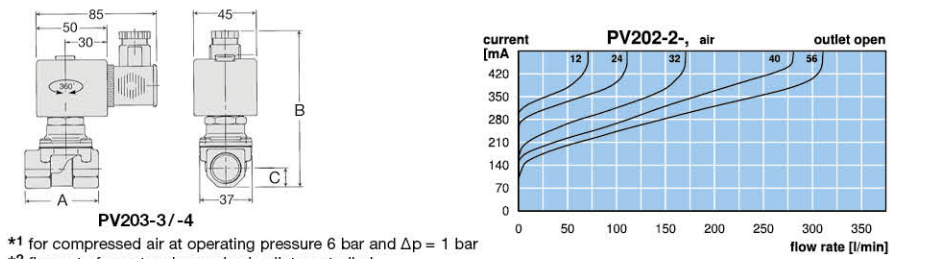
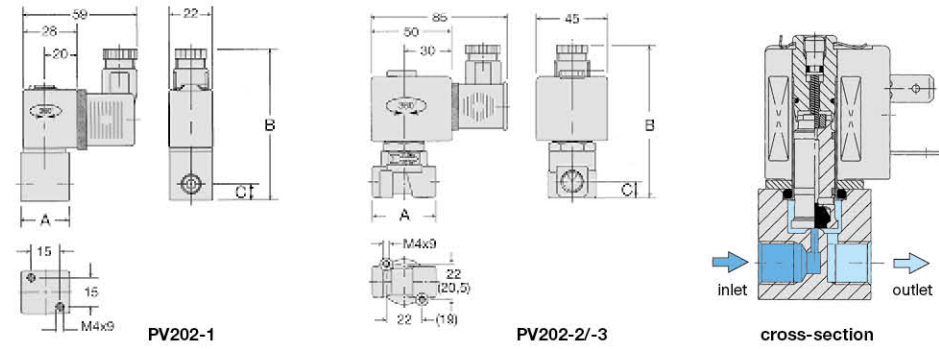

*1 for compressed air at operating pressure 6 bar and $\Delta p = 1$ bar
 *2 flow rate for water since valve is pilot-controlled
 *3 for liquids add W to order number of type PV202-2/-3

Description	Motorised proportional flow valve with low power consumption and resistance to contamination. Throttle setting by wear-resistant control drives made of oxide ceramic. Throttling occurs with drip-tight zero shut-off but no gas tightness.	
Media	compressed air, vacuum or liquids up to viscosity of 40 mm ² /s	Hysteresis ± 4%
Operation	DC, synchronous or stepping motor with standard voltage of 24 V DC or AC ±10% residual ripple. All motors fulfil standards EN50.081-1, EN50.082-2 and 89/336/EEC.	
DC motor (15 / 24)	Motor with feedback potentiometer for servo-amplifier. Resistor 1kΩ ± 20 %, control e.g. by servo-amplifier. Only part of potentiometer range is used. Voltage for potentiometer: 12 V, max. 10 mA.	
DC motor (50 / 51)	With integrated position controller. Setpoint input using jumpers: 0...10 V, 0/4...20 mA. Input resistance: 200 kΩ at voltage signal, 500 Ω at current signal.	
Stepper motor (38)	Bipolar, by means of SAA1042A (Motorola) with drop resistance of 44 Ω per phase at a driver (full-step) operating voltage of 24 V ± 5%. 2028 steps for 90° control disc turn, 200 Hz nominal step frequency.	
Temperature range	10 °C to 90 °C / 14 °F to 194 °F	
Material	Body: brass Elastomer: NBR/Buna-N, optionally FKM or EPDM	Protection class IP 54 Control discs: oxide ceramic

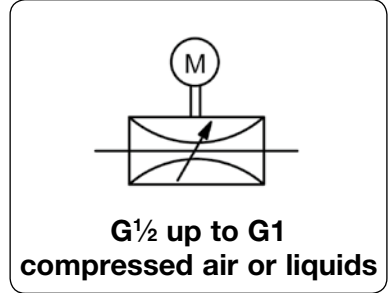

Prop.-V.
11

Dimensions			Nominal size	K _v -value	Flow rate		Supply max.	Connection thread	Order number
A	B	C	DN	(m ³ /h)	water l/min*1	air l/min*1	bar	G	

Proportional flow valve									
DC motor type 15, with potentiometer, 120 Ncm, 24 V DC, switching time 10...14 s*2									
55	147	13	15	1.1	0...20	0...1000	10	G ^{1/2}	P822-15
55	147	13	20	3.4	0...60	0...3000	6	G ^{1/2}	P82A-15
95	164	24	20	4.4	0...70	0...3500	6*3	G ^{3/4}	P823-15
95	164	24	20	4.4	0...70	0...3500	6*3	G1	P824-15



Special options, add the appropriate letter
 cartridge installation instead of thread for DN 15 P825-..

Description	Figure-No.	Watt	Δp max./Torque	Switching time*2
DC motor w/ potentiometer, 120 Ncm	①	1,5 W	6 bar/120 Ncm	10-14 s
DC motor w/ potentiometer, 200 Ncm	①	2,0 W	10 bar/200 Ncm	13 s
DC motor w/ controller	②	3,3 W	16 bar/120 Ncm f. G ^{1/2}	5 s
DC motor w/ controller	②	3,3 W	6 bar/120 Ncm f. G ^{3/4} , G1	5 s
DC motor w/ controller	②	3,8 W	.. bar/ ... Ncm f. G ^{3/4} , G1	.. s
AC motor 50 Hz	③	3,0 W	6 bar/120 Ncm	10 s
stepper motor	④	5,0 W	6 bar/120 Ncm	10 s
FKM elastomer				P82...V
EPDM elastomer				P82...E
free of grease and oil			especially cleaned, suitable for oxygen	P82...L
body nickel-plated				P82...X25

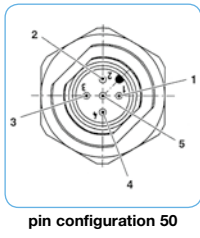
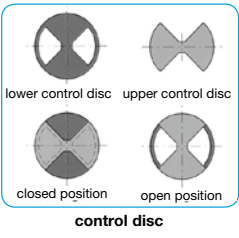
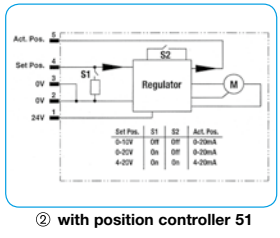
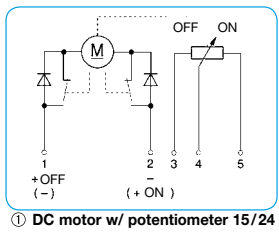
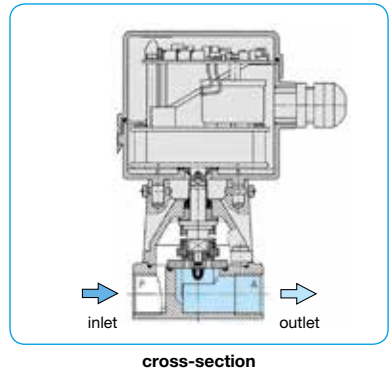

PIN	Description
Pin 1	supply voltage 24 Volt
Pin 2	supply voltage 0 Volt
Pin 3	ground potential for set value input and feedback outlet
Pin 4	set value input 0 - 10 V / 0 (4) - 20 mA
Pin 5	feedback outlet 0 (4) - 20 mA

connection diagram

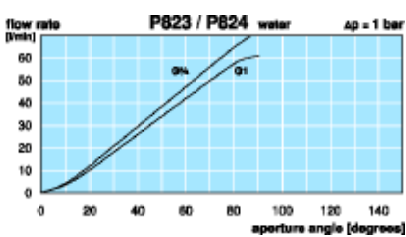
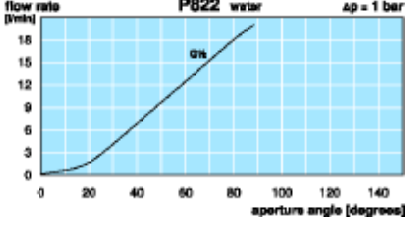
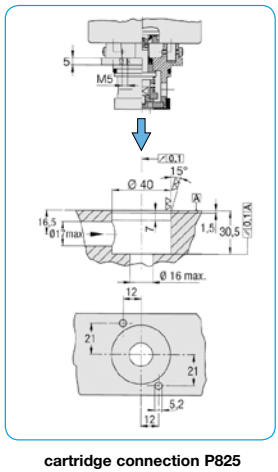
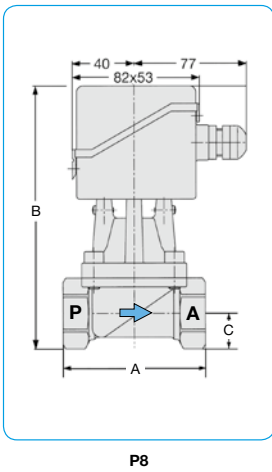
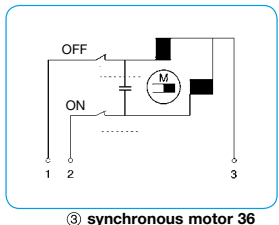

*1 at 6 bar supply pressure and Δp = 1 bar

*2 subject to supply pressure

*3 10 bar at motor for 200 Ncm

PDF CAD
www.aircom.net

Order example:
P822-15



Description	Small proportional flow valve for regulating both air and non-corrosive gases. Voltage signal 10 V as standard or optionally 5 V or 20 V DC.				
Media	50 µm filtered compressed air or non-corrosive gases				
Operating pressure	see chart, max. 7 bar				
Electrical specification	command signal	max. voltage	resistance	current consumption	power consumption
	0 - 5 V DC	0 - 6.2 V DC	13 Ω	0 - 370 mA	1.9 W
	0 - 10 V DC	0 - 12.4 V DC	54 Ω	0 - 185 mA	1.9 W
	0 - 20 V DC	0 - 24.8 V DC	218 Ω	0 - 92 mA	1.9 W
Electrical connection	solder lug or terminal lug, 2.5 x 0.5 mm				
Mounting position	any				
Hysteresis	± 10% FS		Repeatability ± 3% FS		
Temperature range	0 °C to 60 °C / 32 °F to 140 °F				
Material	Body: nickel-plated brass Inner valve: stainless steel and brass		Elastomer: NBR/Buna-N, optionally FKM or EPDM		

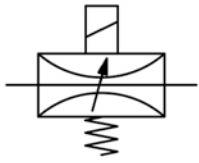

DN 0.2 up to DN 1.5
0 - 5 / 10 / 20 V DC

Dimensions			Nominal	K _v -	Flow	Operating	Connection	Order
A	B	C	size	value	rate	pressure	thread	number
mm	mm	mm	DN	(m³/h)	l/min*1	max. bar	M5	

Volume flow regulator M5								0-10 V DC, 2-port/2-way valve for compressed air or non corrosive gases, with terminal lug, brass, NBR/Buna-N	PVK
20	40	5	0.2	0.03	0...3	1.7	M5	PVK-092	
						3.5		PVK-093	
						7.0		PVK-097	
20	40	5	0.3	0.07	0...7	1.7	M5	PVK-132	
						3.5		PVK-133	
						7.0		PVK-137	
20	40	5	0.6	0.24	0...24	1.7	M5	PVK-252	
						3.5		PVK-253	
						7.0		PVK-257	
20	40	5	1.0	0.18	0...19	1.7	M5	PVK-402	
						3.5		PVK-403	
20	40	5	1.5	0.14	0...14	1.7	M5	PVK-602	



PVK-257
with M5 connection



PVK-092AF
with flange connection

Special options, add the appropriate letter

0 - 5 V	input signal max. 6,2 V,	0 - 370 mA,	13 Ω	PVK-. . . A
0 - 20 V	input signal max. 25 V,	0 - 92 mA,	218 Ω	PVK-. . . C
flange connection	for panel mounting			PVK-. . . F
FKM elastomer				PVK-. . . V
EPDM elastomer				PVK-. . . E

Accessories, enclosed

manifold block for valve with flange connection, for 2, 4 ... 12 valves

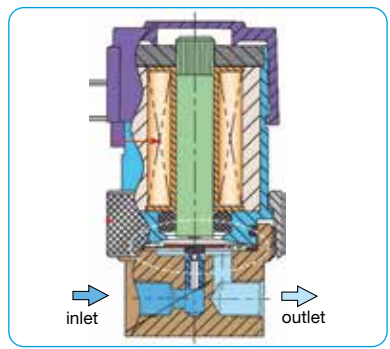
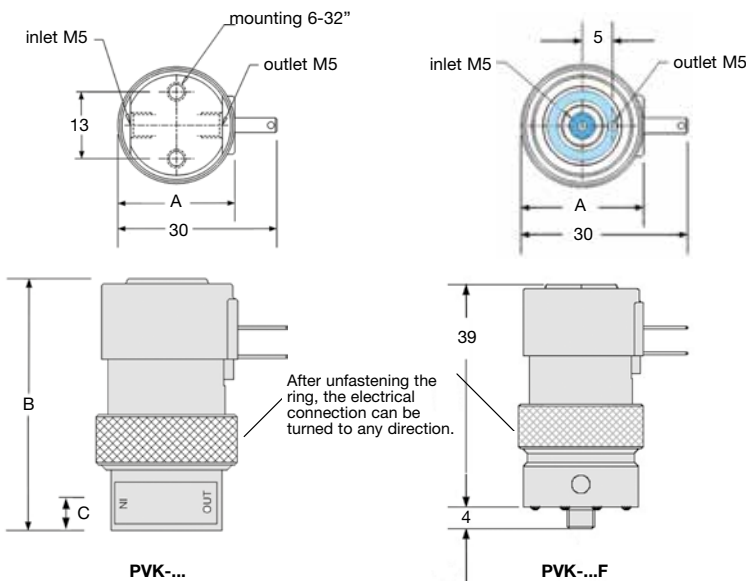

cross section

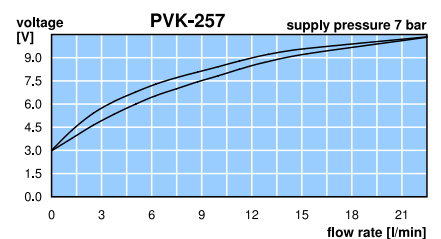

*1 at max. current consumption and max. operating pressure

Description	Compact positioner with analogue control. Compressed air for remote control necessary. The stroke is made proportional to the flow through the parabolic contour of the piston. The valve shuts tight and is of anti-water hammer design.	
Media	compressed air, vacuum up to 10 ⁻² mbar or liquids up to viscosity of max. 600 cST (mm ² /s)	
Control	pneumatic:	lubricated, unlubricated and 50 µm filtered compressed air, 4...8 bar, port G ³ / ₈
	electrical:	0-10 V, optionally 4-20 mA, supply 24 V DC ± 10%, power consumption 150 mA/3.6 W
Control element	2-port/2-way valve, NC (normally closed) as standard, as option 3-port/2-way valve for mixing different media, with standard piston cable gland, optionally M12	
Electrical connection	any	Protection Class IP 66
Mounting position		Repeatability < 1.0% FS
Linearity / Hysteresis	< 2% FS	
Fail-safe	valve closes (NC) in the event of voltage failure, optionally outlet fail freeze feature	
Temperature range	Ambient: 0 °C to 50 °C / 32 °F to 122 °F	Medium: -10 °C to 180 °C / 14 °F to 356 °F
Material	Control valve body: bronze, optionally SST 316L	Cone seal: PTFE
	Proportional valve body: aluminium, PA and FV	

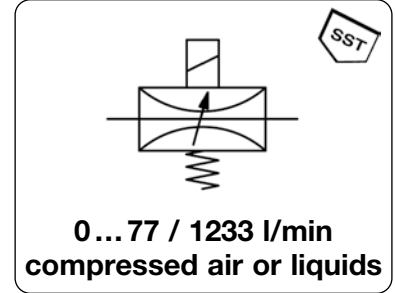

Prop.-V.
11

Dimensions			Nominal size	K _v -value	Supply max.	Flow rate		Connection thread	Order number
A	B	Ø*1	DN	(m ³ /h)	bar	water l/min	air l/min	G	

Volumenstromregler										PVE
2/2-Wege, NC, Bronze, Steuerdruck 4...8 bar, für Luft oder Wasser, 0-10 V, 24 V DC, failsafe										
65	155	63	15	4.6	10	0...	14	5 000	G1/2	PVE1-04B
75	185	63	20	7.1	16	0...	118	7 700	G3/4	PVE1-06C
90	209	90	25	15	16	0...	250	16 250	G1	PVE1-08D
110	246	90	32	21	12	0...	350	22 750	G1 1/4	PVE1-10D
110	298	125	32	22	16	0...	367	23 800	G1 1/4	PVE1-10E
120	245	63	40	29	4	0...	483	31 400	G1 1/2	PVE1-12C
120	262	90	40	29	8	0...	483	31 400	G1 1/2	PVE1-12D
120	314	125	40	44	16	0...	733	47 600	G1 1/2	PVE1-12E
150	259	63	50	40	2	0...	667	43 300	G2	PVE1-16C
150	276	90	50	40	6	0...	667	43 300	G2	PVE1-16D
150	328	125	50	66	10	0...	1 100	71 500	G2	PVE1-16E
190	300	90	65	68	2	0...	1 133	73 600	G2 1/2	PVE1-20D
190	352	125	65	74	6	0...	1 233	80 000	G2 1/2	PVE1-20E



Special options, add the appropriate letter

- 3-port/2-way valve** for mixing different media, bronze version only
 - fail freeze** if supply voltage fails, outlet pressure will be frozen
 - SST body** stainless steel 316L, material no. 1.4401
 - 4-20 mA** input signal
 - for oxygen *2** specially cleaned, with oxygen grease, for G¹/₂ to G2
 - cascade control** double loop, 0-10 V double loop, 4-20 mA double loop, frequency input
 - electr. connection M12** with coupling socket
- PVE3-... 3
 - PVE-... S
 - PVE-... I
 - PVE-... 15
 - PVE-... KU
 - PVE-... KI
 - PVE-... KF
 - PVE-... M12

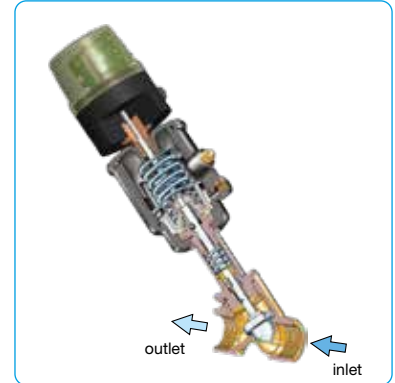

PVE with regulator control	
1	24 V DC supply voltage
2	GND (earth) supply
3	+ setpoint (0-10 V / 4-20 mA)
4	GND (earth) setpoint
5	
6	position feedback
7	+24 V DC ON/OFF output signal

PVE with cascade control	
1	24 V DC supply voltage
2	GND (earth) supply
3	+ setpoint (0-10 V / 4-20 mA)
4	GND (earth) setpoint
5	external signal input
6	
7	+24 V DC ON/OFF output signal

connecting plan

Ø head*1	thread	C	D	ØF
50 mm	1/2	213	212	69
63 mm	3/4	242	245	85
	1 1/2	287	294	85
	2	296	319	85
90 mm	1	261	267	118
	1 1/4	293	306	118
	1 1/2	304	313	118
	2	313	337	118
	2 1/2	329	369	118
125 mm	1 1/4	445	354	156
	1 1/2	356	361	156
	2	365	385	156
	2 1/2	380	417	156

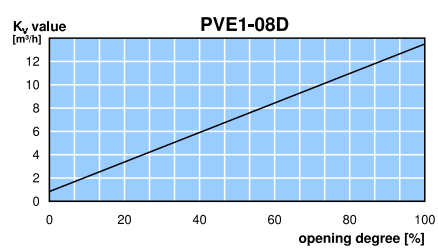
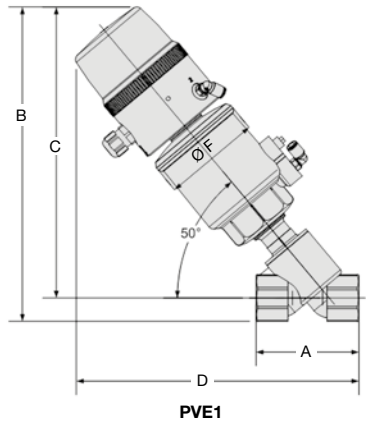

*1 Ø of pilot head
*2 max. 15 bar operating pressure and 60 °C / 140 °F media temperature

PDF CAD
www.aircom.net

Order example:
PVE1-04B



Description The flow control valve functions as a pinch valve in a new design of housing with full flow cross-section. Since the straight valve passage has neither constrictions nor back-points, there is no danger of clogging or blockage. Frictional loss is at a minimum.

Media Compressed air, non-corrosive gases, liquids or other paste-like or powdery media. Solids are enclosed by the flexible sleeve at shut-off.

Sleeve Highly flexible with double-woven reinforcement in eight different grades. Sleeve simple to change.

Pressures Operating pressure: max. 4.0 bar Pilot pressure: max. 6.5
Differential pressure: max. 2.5 bar Closing pressure: $P_1 + 2.5$ bar from DN32, $P_1 + 2$ bar from DN40 on

Vacuum If vacuum is greater than -100 mbar, vacuum compensation should be provided on the control side.

Accuracy In the flow range of 0 to 70% the accuracy of the linearity of pilot pressure to flow is approx. 10%.

Mounting position any

Temperature range 0 °C to max. 100 °C / 32 °F to max. 212 °F, subject to sleeve material

Material Body: POM at model QP or aluminium die-cast at model QS Sleeve: depending on selected version

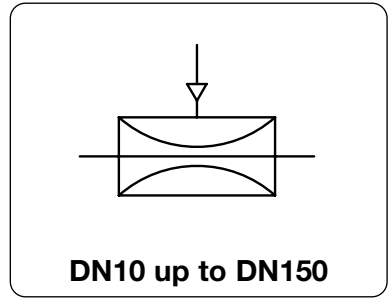

Dimensions		Nominal size DN	Volume of control chamber l	Pilot port G	Operating pressure max. bar	Connection thread G / flange	Order number
A mm	Ø mm						

Flow control valve							operating pressure max. 4 bar, pilot pressure max. 2.5 bar above operating pressure	Q
80	44	10	0.03	G¼	4	G¾	QP10 -03NR	
95	50	15	0.04	G¼	4	G½	QP15 -04NR	
110	58	20	0.05	G¼	4	G¾	QP20 -06NR	
125	65	25	0.07	G¼	4	G1	QP25 -08NR	
140	83	32	0.10	G¼	4	G1¼	QP32 -10NR	
150	95	40	0.13	G¼	4	G1½	QP40 -12NR	
200	100	50	0.23	G¼	4	G2	QS50 -16NR	
240	134	65	0.49	G¼	4	G2½	QS65 -20NR	
290	154	80	0.95	G¼	4	G3	QS80 -24NR	
280	220	100	1.80	G¾	4	flange	QS100-FLNR	
350	250	125	3.30	G¾	4	flange	QS125-FLNR	
420	285	150	6.40	G¾	4	flange	QS150-FLNR	



Special options, add the appropriate letter

- flange connection** according to DIN 2532, PN10 from G1¼ on Q ... -FL ...
- sleeve NR** natural rubber, black 80 °C / 176 °F Q ... -NR
- sleeve NRL** rubber, suitable for food, black 70 °C / 158 °F Q ... -NL
- sleeve NRLH** rubber, suitable for food, light 70 °C / 158 °F Q ... -NH
- sleeve NBR** nitrile rubber / Buna-N, suitable for food 80 °C / 176 °F Q ... -NB
- sleeve EPDM** ethylene-propylene rubber, suitable for food, black 100 °C / 212 °F Q ... -EP
- sleeve FKM** fluorine rubber, black 100 °C / 212 °F Q ... -FK
- sleeve CR** chloroprene rubber / neoprene, black 80 °C / 176 °F Q ... -CR
- sleeve CSM** natural rubber, chlorosulphonyl polyethylene 80 °C / 176 °F Q ... -CS

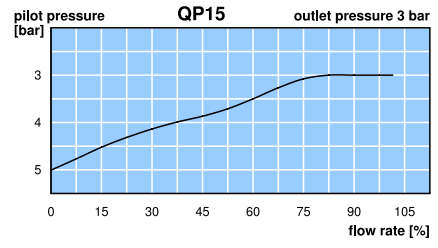
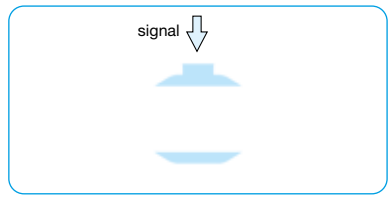
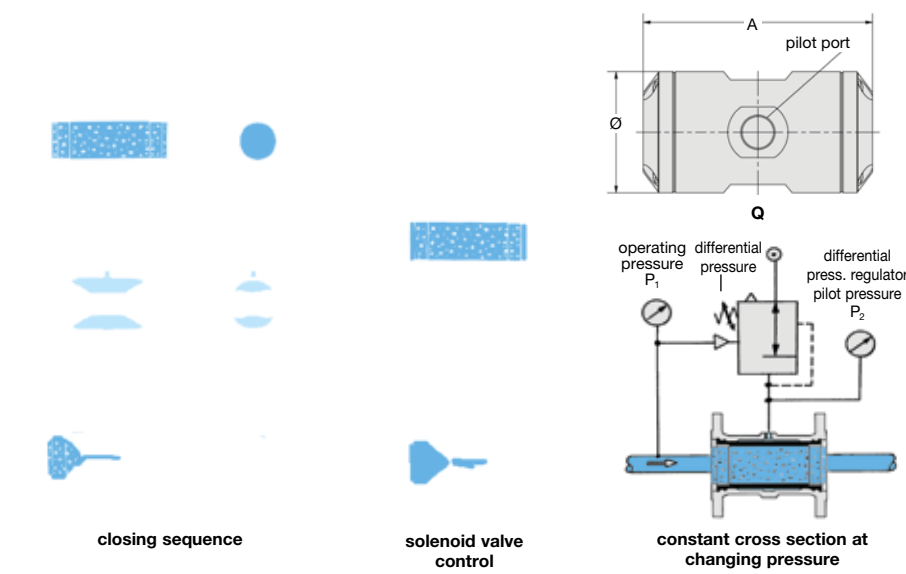

Stainless steel pinch valves: see chapter for stainless steel devices

PDF CAD
www.aircom.net

Order example:
QP10-03NR